

真空镀版图面

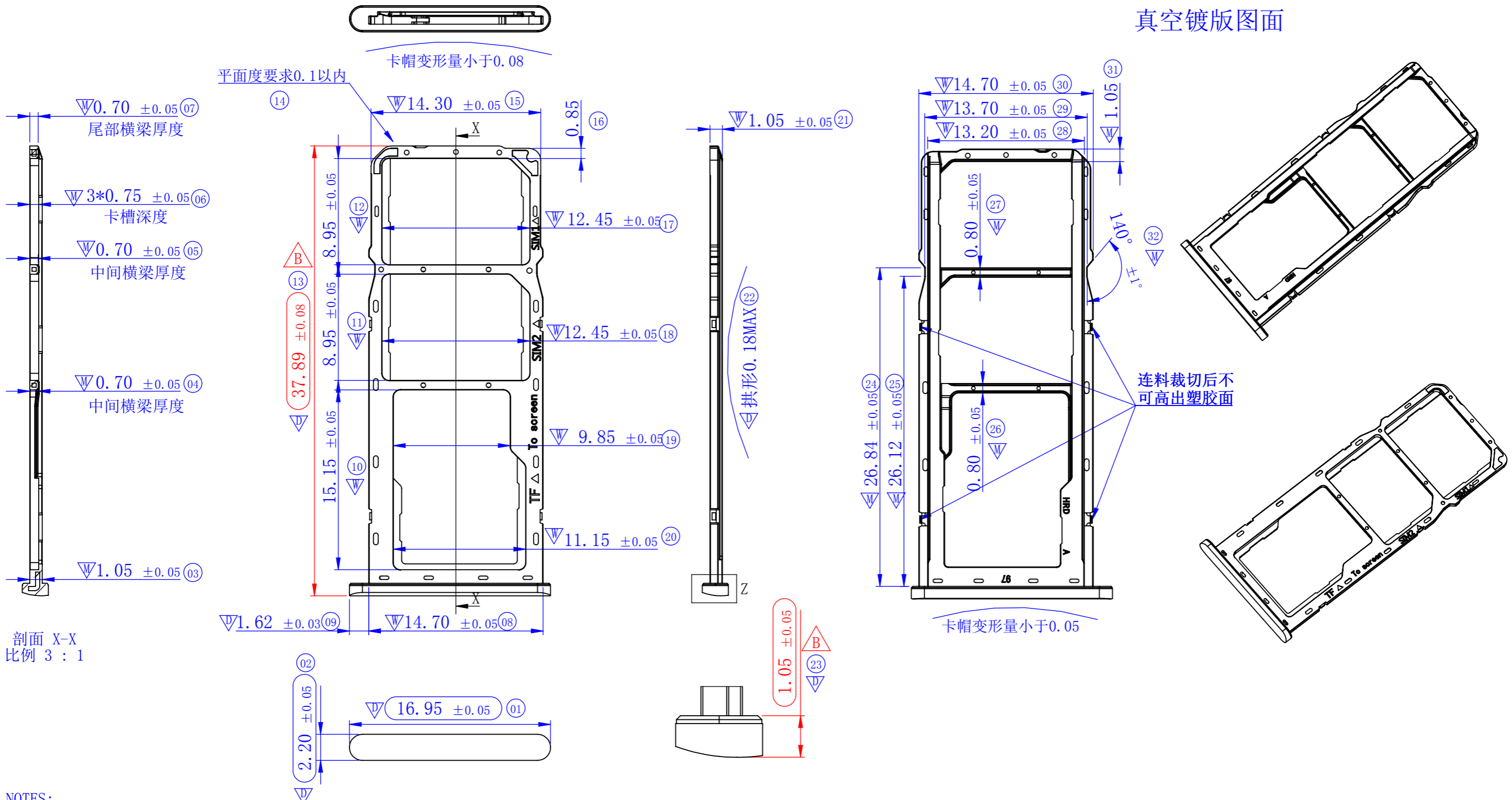

- NOTES:
1. 塑胶材质: PC; 原料颜色: 黑色
钢片材质: T=0.35mm;
外观处理要求: 金色/腮红金色/水鸭绿色/无烟灰色
 2. GP PASSED ACCORD WITH HRD-RoHS-219 STANDARD.
 3. CAMBER OF CARRIER TO BE 10mm MAX. /m.
 4. THE BURR MUST BE LESS THAN 0.03mm.
 5. ALL DIMENSIONS MARKED ∇ MUST BE CONTROLLED BY QC.
MARKED ∇ PER WORD WEEK AND ∇ PER MONTH MUST BE CONTROLLED.
 6. ALL DIMENSIONS MARKER (XX) MUST BE MEASURE BY FAI.
 7. 产品表面不得有划伤、油污、缺胶、扭曲变形、裂痕等缺陷。
 8. 产品表面需镭射字符, 详细见图纸字符。

序号	成品料号	颜色
1	KT097-KCA13020	金色
2	KT097-KCP13020	腮红金色
3	KT097-KCJ13020	水鸭绿色
4	KT097-KCH13020	无烟灰

REV.	ECN NO.	DESCRIPTION	DATE	REV. A	FINISH: SEE NOTE	客户图
B	E1912713A	客户设变, 卡帽外观面加胶0.05mm	12/10/2019	3 / 1		
A	-----	新版发行	08/21/2019	1 / 1		

UNITS: mm	GENERAL TOLERANCE		DRAW:	PART NO: KT097-KCX13020
DATE: 06/26/2019	X. ±0.15	X° ±3.00°	CHECKED:	TITLE: 三选一体式卡托
SCALE: 3 / 1	.X ±0.10	.X° ±2.00°	APPROVE:	DRAWING NO: C-KT097-0000
	.XX ±0.05	.XX° ±1.00°		
	.XXX ±0.02	.XXX° ±0.50°		

 昆山捷皇电子精密科技有限公司
HONGRIDA ELECTRONIC TECHNOLOGY CO.,LTD.